

Specifications Aerosol Bottoms, Diameter 50 mm L

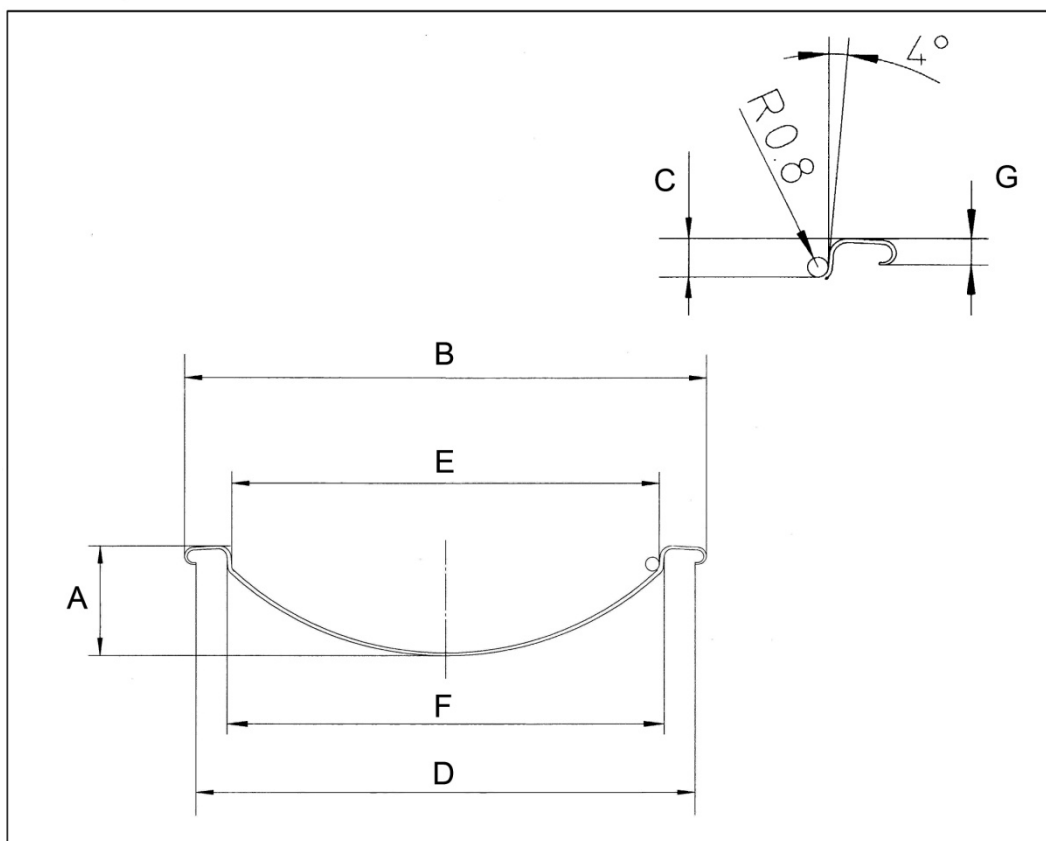

Specifications	18 bar		15 bar	
	SIZE	TOLL.	SIZE	TOLL.
A	12,55	±0,15	12,55	±0,15
B	60,00	±0,15	60,00	±0,15
C	3,10	±0,15	3,10	±0,15
D	57,60	Min.	57,60	Min.
E	49,43		49,43	
F	50,26		50,26	
G	2,00	±0,15	2,00	±0,15
THICKNESS	0,30		0,27	
HARDNESS	TH460CA		TH460CA	

All units are to be understood in millimeters.